

SUN2000-(25KTL, 30KTL)-US Quick Installation Guide

Issue: 04
Part Number: 31507215
Date: 2019-06-30

HUAWEI TECHNOLOGIES CO., LTD.



NOTICE

1. The information in this document is subject to change without notice. Every effort has been made in the preparation of this document to ensure accuracy of the contents, but all statements, information, and recommendations in this document do not constitute a warranty of any kind, express or implied.
2. Before installing the device, read the *SUN2000-(25KTL, 30KTL)-US User Manual* for knowledge of product information and safety precautions.
3. Only qualified and trained electrical technicians are allowed to operate the device. Operators should understand the components and functioning of a grid-tied PV power system, and they should be familiar with relevant local standards.
4. Before installing the device, check that deliverables are intact and complete against the packing list. If any damage is found or any component is missing, contact the dealer.
5. Use insulated tools when installing the device. For personal safety, wear insulation gloves and protective shoes.
6. When installing devices or connecting cables, use appropriate tools and take necessary protective measures to avoid damaging devices during operation.
7. Huawei shall not be liable for any consequence caused by violation of the storage, transportation, installation, and operation regulations specified in this document and the user manual.

1 Product Overview

Front View

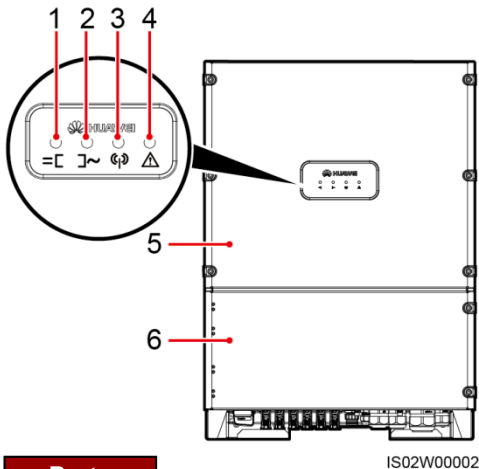

- (1) PV connection indicator
- (2) Grid-tied indicator
- (3) Communications indicator
- (4) Alarm/Maintenance indicator
- (5) Host panel
- (6) Maintenance compartment door

Ports

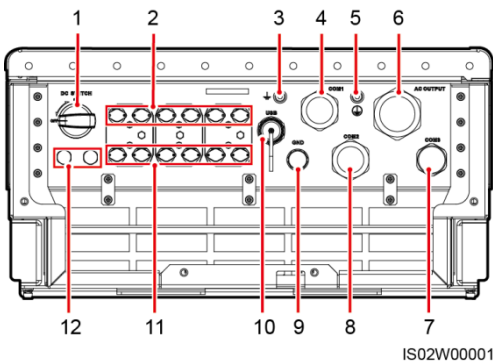

- (1) DC switch (DC SWITCH)
- (2) Positive DC terminal (+)
- (3) Functional ground point
- (4) Waterproof cable connector (COM1)
- (5) Protective ground point
- (6) Waterproof cable connector (AC OUTPUT)
- (7) Waterproof cable connector (COM3)
- (8) Waterproof cable connector (COM2)
- (9) Waterproof cable connector (GND)
- (10) USB port (USB)
- (11) Negative DC terminal (-)
- (12) Ventilation valve

2 System Installation

2.1 Determining the Installation Position

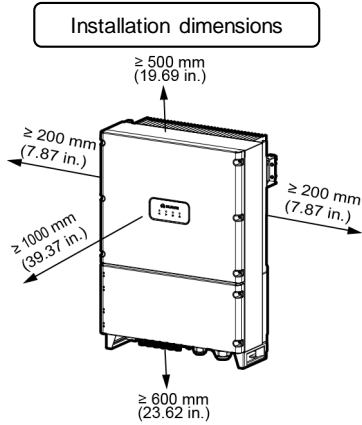

IS02SC0004

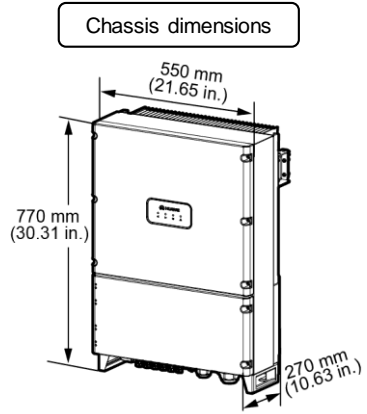

IS02WC0006

2.2 Determining the Installation Mode

NOTE

It is recommended that the inverter be installed vertically or with a back tilt of no more than 15 degrees for optimal heat dissipation conditions.

Installed on a Common Support

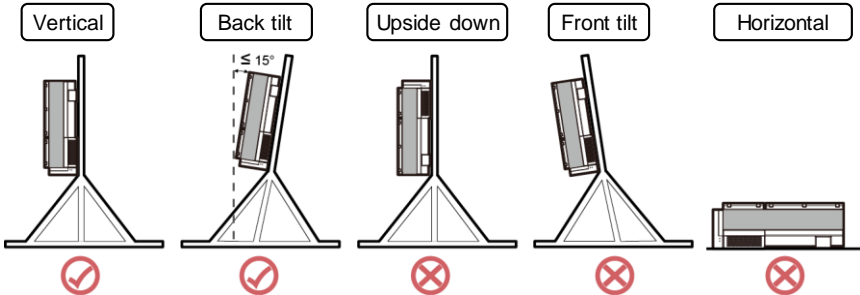

Installed on a Wall

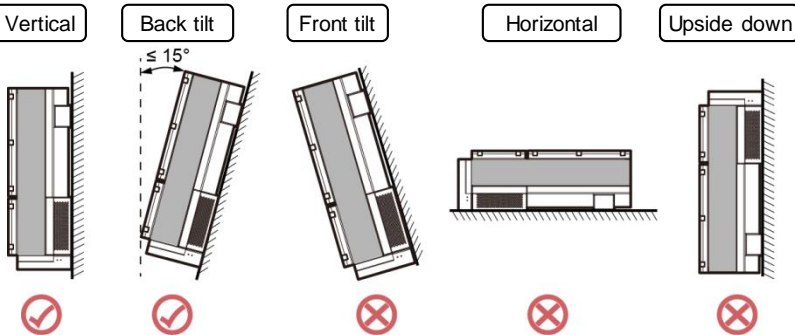

IS02HC0003

Installed on a Tilted Support

Back tilt

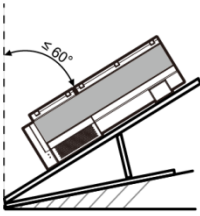

Front tilt

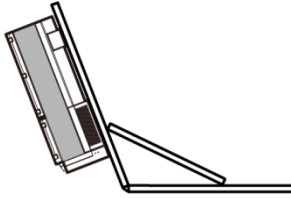

Horizontal



Upside down

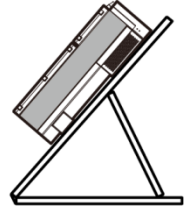

IS02HC0023

2.3 Installing an Inverter

Installed on a Common Support

1. Determine the hole positions on the support based on rear panel dimensions.

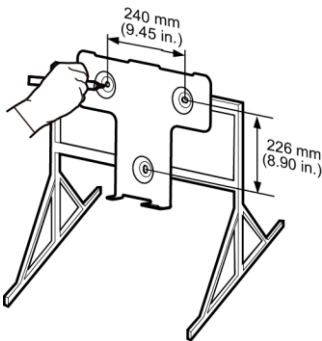

IS02HC0011

2. Drill holes.

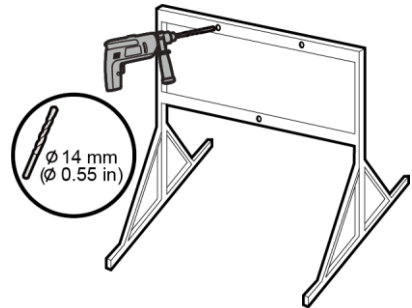

IS01HC0017

3. Secure the rear panel.

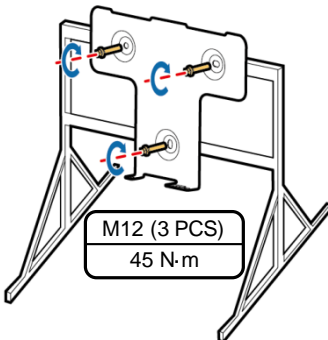

IS01HC0012

4. Mount the inverter on the rear panel.

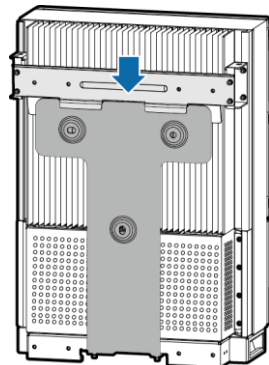

IS02H00001

5. Tighten hexagon bolts.

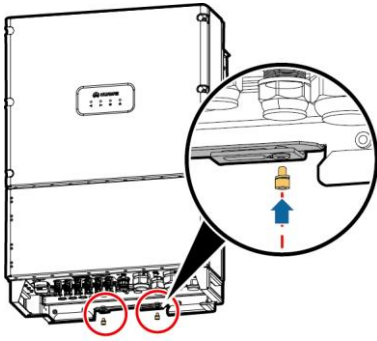

IS02HC0010

6. (Optional) Install an anti-theft lock.

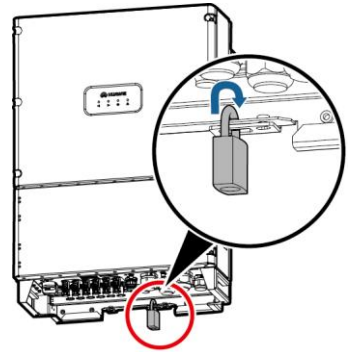

IS02HC0009

NOTE

The anti-theft lock is prepared by the customer.

Installed on a Wall

1. Determine the positions for drilling holes on the wall according to the rear panel dimensions.

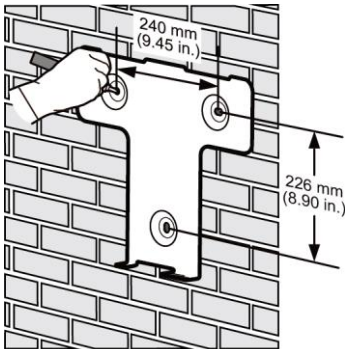

IS01SC0020

2. Drill holes and install expansion sleeves for expansion bolts.

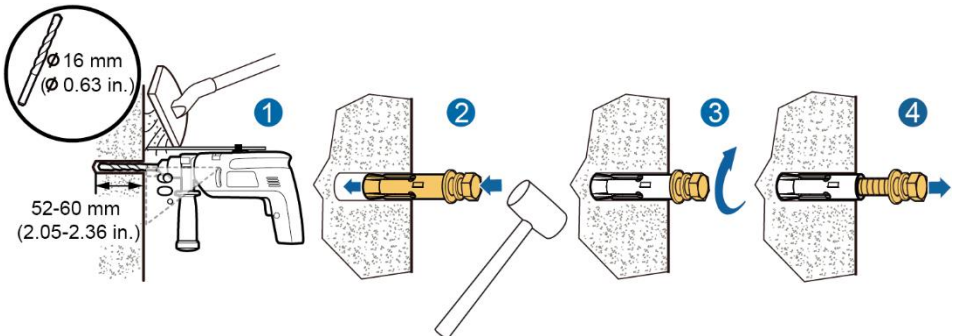

IS03H00001

3. Secure the rear panel.

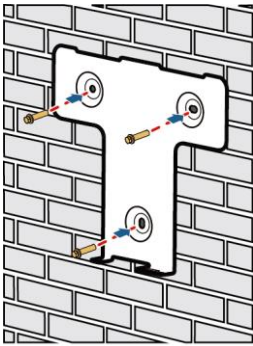

IS01HC0005

M12 (3 PCS)
45 N·m

4. Mount the inverter on the rear panel.

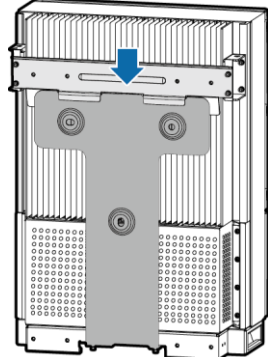

IS02H00001

5. Tighten hexagon bolts.

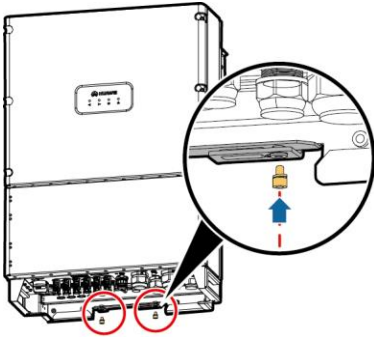

IS02HC0010

6. (Optional) Install an anti-theft lock.

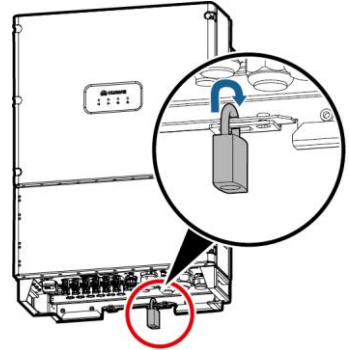

IS02HC0009

NOTE

The anti-theft lock is prepared by the customer.

Installed on a Tilted Support

1. Prepare a tilted support.

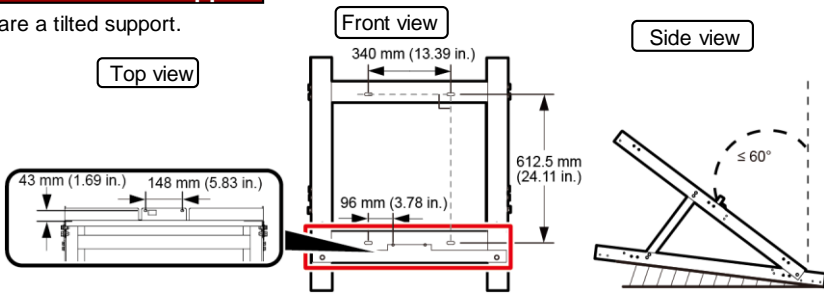

IS01HC0069

NOTE

1. The hole dimensions of the bottom auxiliary tightening point in the top view are OB-13 mm x 8 mm (OB-0.51 in. x 0.31 in.).
2. The hole dimensions of the tightening point for the tilted support mounting kit in the front view are OB-32 mm x 12 mm (OB-1.26 in. x 0.47 in.).
3. The auxiliary tightening point is 5 mm (0.20 in.) away from the lower tightening point for the tilted support mounting kit.

2. Secure the tilted support mounting kit to the inverter. 3. Secure the inverter to the tilted support.

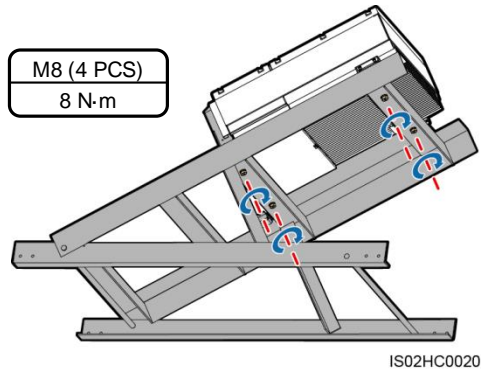
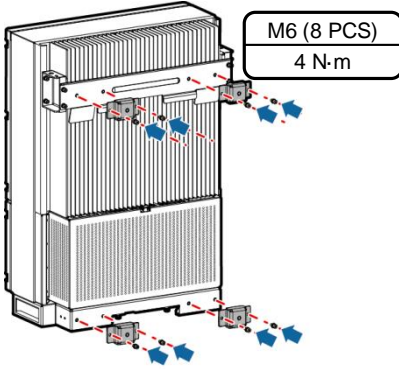

4. (Optional) Secure the auxiliary screws to the inverter. 5. (Optional) Install an anti-theft lock.

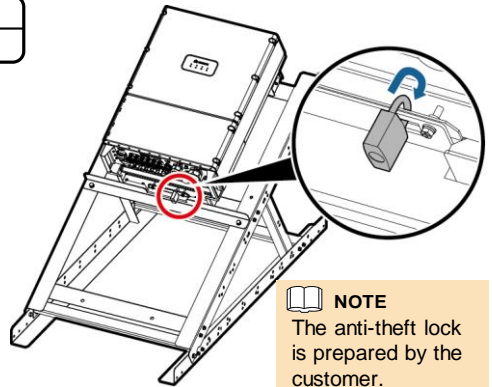
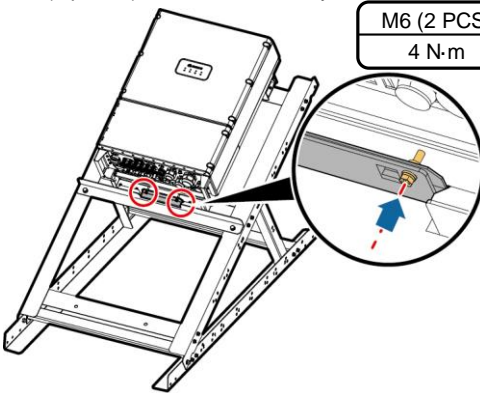

3 Electrical Connection

NOTICE

Electrical connections must meet local installation regulatory requirements.

3.1 Installing Ground Cables

1. Remove the two screws from the maintenance compartment door using a hex key and set them aside.

WARNING

1. Do not leave unused screws in the chassis.
2. Do not open the host panel of the inverter.
3. Before opening the maintenance compartment door, turn off the downstream AC output circuit breaker and DC switch on the inverter.

NOTE

The hex key is stored in the fitting bag bound to the chassis base.

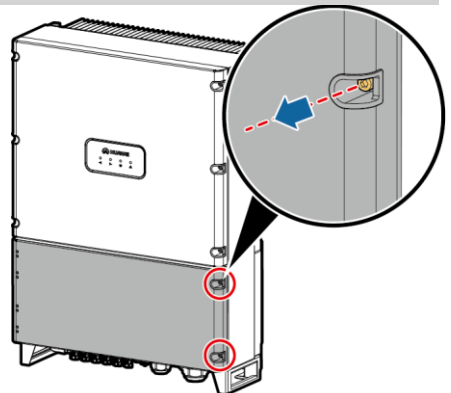

2. Open the maintenance compartment door and adjust the support bar.

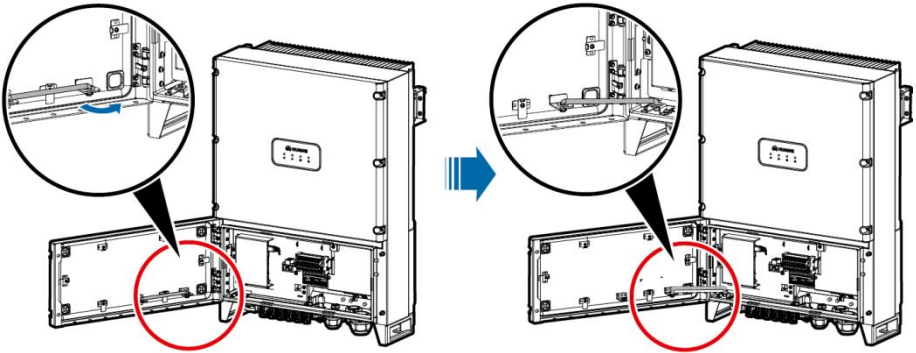

3. Remove the AC terminal cover and set it aside.

IS02HC008

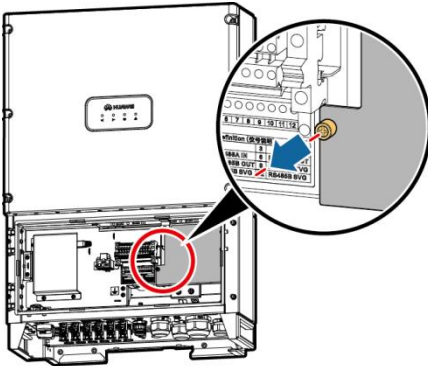

4. Install ground cables.

IS02HC007

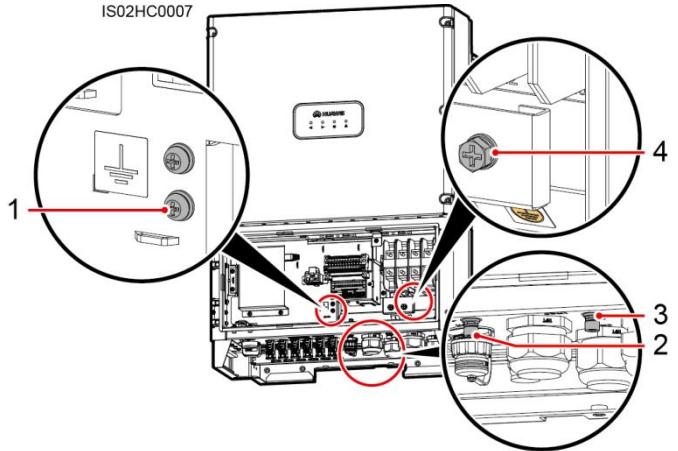

IS02WC007

Ground Point	Meaning	Ground Point Screw Model	Connection
1	PV side ground points	M4	Connect either of the two ground points for PV side grounding.
2		M6	
3	Protection ground points	M6	Connect either of the two ground points for protective grounding.
4			

NOTE

1. Select ground points for PV side grounding and protective grounding based on the principle of easy operation.
2. It is recommended that 8 AWG outdoor copper-core cables be used as ground cables. Ground cables must be securely connected.
3. It is recommended that ground cables of the inverter be connected to the near end.
4. To prevent corrosion, apply silica gel or paint to the PE terminal after connecting the ground cables.

Installing Ground Cables (Ground Points 1 and 4 Are Used as an Example)

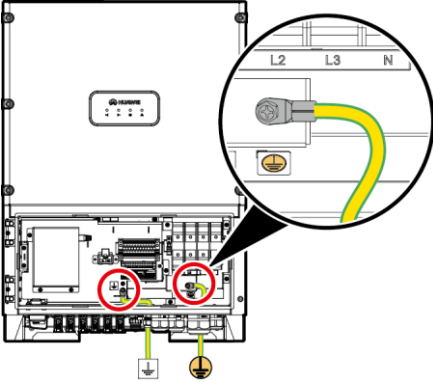

IS021C0005

Ground Point	OT Terminal	Tightening Torque
1	M4	1.2 N·m
4	M6	5 N·m

NOTE

1. Route the PV module ground cable through the GND hole at the inverter bottom.
2. Route the protective ground cable through the AC OUTPUT hole at the inverter bottom.
3. When connecting the PE cable to the ground point 4, if the SUN2000 is insecurely installed and the AC output power cable bears the pulling force, ensure that the last cable bearing the force is the PE cable.

3.2 Installing AC Output Power Cables

Cable Type	Cable Quantity	Recommended Cable Specifications
A single cable	Four (L1, L2, L3, and N) or three (L1, L2, and L3)	4 AWG

NOTE

1. The SUN2000-25KTL/30KTL-US (SUN2000 for short) supports three-phase, four-wire (L1, L2, L3, and N) and three-phase, three-wire (L1, L2, and L3) output modes. Use a connection mode according to the local and national regulations and installation specifications.
2. Use copper cables that can withstand 90°C (194°F) or 105°C (221°F).
3. It is recommended that the AC output cable be routed through a pipe for protection.
4. The table lists only the recommended cable specifications. For more information about cable specifications, see the *SUN2000-(25KTL, 30KTL)-US User Manual*.

1. Remove the waterproof cable connector from AC OUTPUT.
2. Route the AC output power cable through the prepared cable routing pipe.
3. Route the AC output power cable and the cable routing pipe through the AC OUTPUT hole at the inverter bottom.
4. Prepare AC output power cables. Use hydraulic pliers to crimp the conductor part of the OT terminal and cover the crimping area with heat shrink tubing or PVC insulation tape.

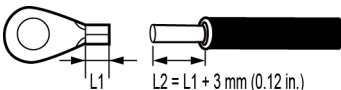

IS022C0001

NOTE

1. The OT terminal type is M6.
2. If heat shrink tubing is used, put it through the power cable and then crimp the OT terminal.

5. Connect the SUN2000 AC output power cables to the AC terminal block one by one.

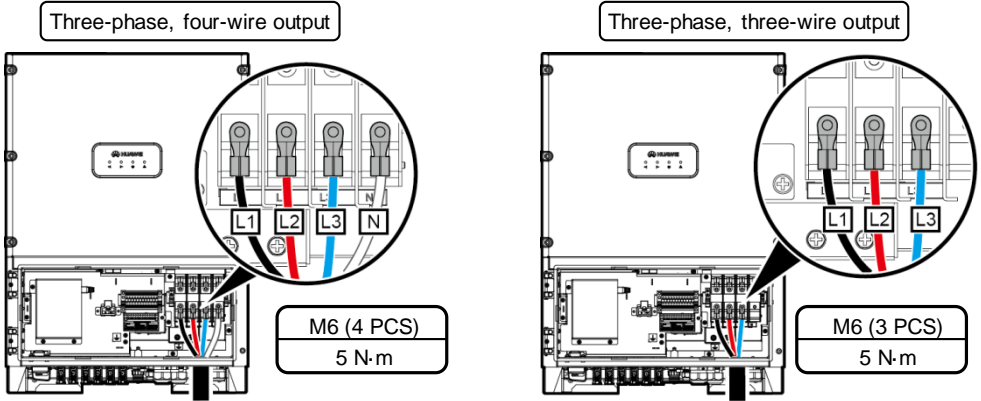

IS021C0007

IS02110001

NOTE

Adjust the sequence of installing AC output power cables based on site requirements.

NOTICE

1. The AC output power cable must be secured to a torque that does not exceed 6 N·m. Otherwise, the AC terminal block may be damaged.
2. Ensure that the AC output power cable is securely connected. Otherwise, the inverter may fail to run or the terminal block may be damaged after the inverter operates.
6. Secure the cable routing pipe.

3.3 Installing DC Input Power Cables

Optional DC input terminals

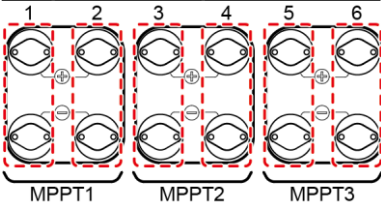

Number of Inputs	SUN2000-25KTL/30KTL-US
1	Connects to any one route
2	Connects to routes 1 and 3
3	Connects to routes 1, 3, and 5
4	Connects to routes 1, 2, 3, and 5
5	Connects to routes 1, 2, 3, 4, and 5
6	Connects to routes 1, 2, 3, 4, 5, and 6

NOTE

Routes 1, 2, 3, 4, 5, and 6 are defined from left to right.

WARNING

- Ensure that the PV module output is well insulated to ground.
- Before inserting the positive and negative connectors respectively into the positive and negative DC input terminals of the inverter, check that the DC voltage does not exceed 1000 V using a multimeter. Otherwise, the inverter will be damaged.

NOTICE

1. Use the positive and negative metal contacts and DC connectors supplied with the SUN2000. Using other models of positive and negative metal contacts and DC connectors may result in serious consequences. The caused device damage is not covered under any warranty or service agreement.
2. The metal contacts supplied with the DC connectors are either cold forming contacts or stamping forming contacts. Crimp the metal cold forming contacts using crimping tool UTXTC0005 (Amphenol, recommended) or H4TC0001 (Amphenol). Crimp the metal stamping forming contacts using crimping tool H4TC0003 (Amphenol, recommended), H4TC0002 (Amphenol), PV-CZM-22100 (Staubli), or PV-CZM-19100 (Staubli). When choosing PV-CZM-22100 or PV-CZM-19100, do not use the locator. Otherwise, metal contacts would be damaged.
3. Before connecting DC input power cables, mark the polarities on the cables to ensure that the cables are connected correctly. If the cables are connected incorrectly, the device may be damaged.
4. Insert the crimped metal terminals of the positive and negative power cables into the appropriate positive and negative connectors. Then pull back the DC input power cables to ensure that they are connected securely.
5. Connect the positive and negative connectors to the appropriate positive and negative DC input terminals. Then pull DC input power cables to ensure that they are connected securely.
6. If the DC input power cables are reversely connected and the DC SWITCH is ON, do not turn off the DC SWITCH immediately. Otherwise, the inverter may be damaged and the damage is beyond the warranty scope. Wait until the PV string voltage reduces to the safety range (below 60 V DC). Then, turn off the DC SWITCH, remove the positive and negative connectors, and rectify the connection.

Installing a DC input power cable (using metal cold forming contacts)

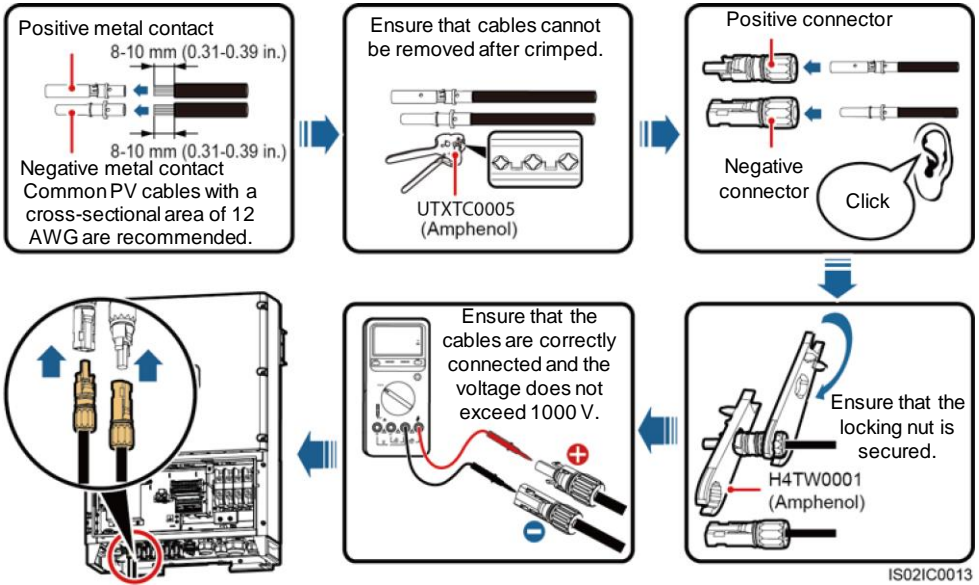

Installing a DC input power cable (using metal stamping forming contacts)

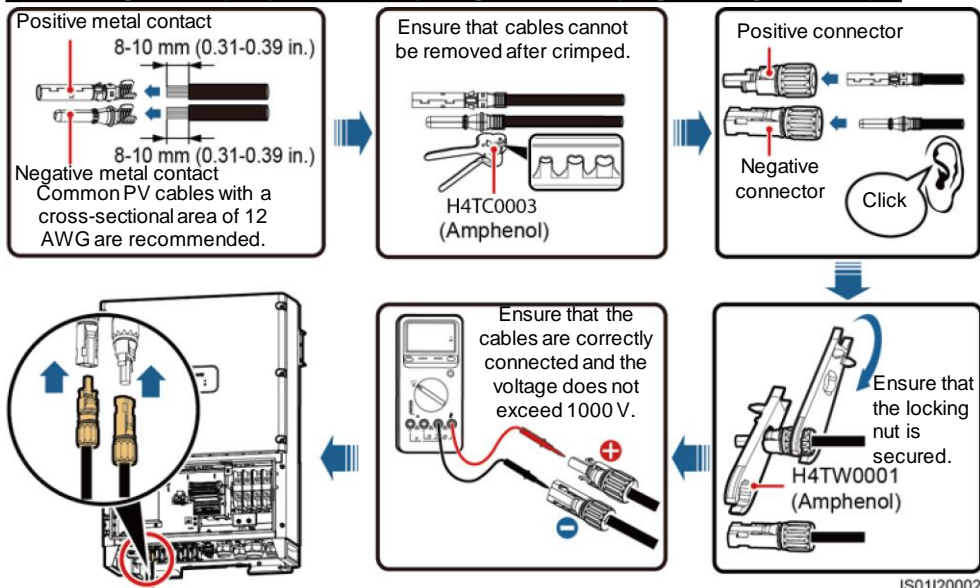

3.4 Selecting a Communication Mode

Model	Communication Mode		Remarks
	RS485 Communication	PLC (MBUS) Communication	
SUN2000-25KTL/30KTL-US	Supported	Supported	<ol style="list-style-type: none"> Only one communications mode can be selected in practice. If PLC (MBUS) is used, do not connect the RS485 communications cable.
SUN2000-25KTL/30KTL-US	Supported	Not supported	N/A

3.5 Installing RS485 Communications Cables

NOTICE

When routing communications cables, ensure that communications cables are separated from power cables and away from interfering source to prevent communication from being affected.

NOTE

- If RS485 is used, connect the RS485 communications cable. If PLC (MBUS) is used, do not connect the communications cable.
- The RS485 communications cable can connect to either a terminal block or an RJ45 network port. Use one connection mode in practice. Connecting to the terminal block is recommended.
- If the RS485 communications cable is required, you are advised to route the RS485 communications cable through a pipe. Before connecting cables, remove the corresponding waterproof cable connectors.

Method 1: Connecting to the Terminal Block (Recommended)

The DJYP2VP2-22 2 x 2 x 1 cable or a communications cable with a wire sectional area of 1 mm² (0.00155 in.²) and external diameter of 14–18 mm (0.55–0.71 in.) is recommended.

1. Peel off the RS485 communications cables.

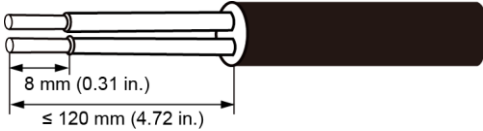

2. Connect the RS485 communications cables.

IS02ZC0002

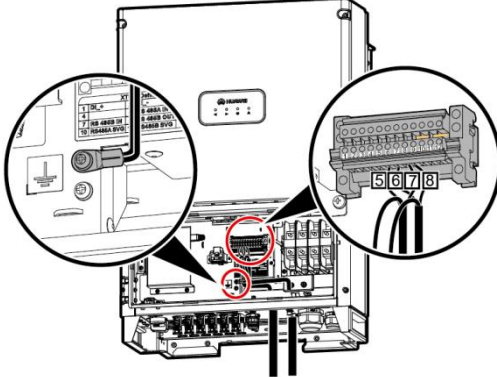

IS02IC0009

3. Bind the RS485 communications cables.

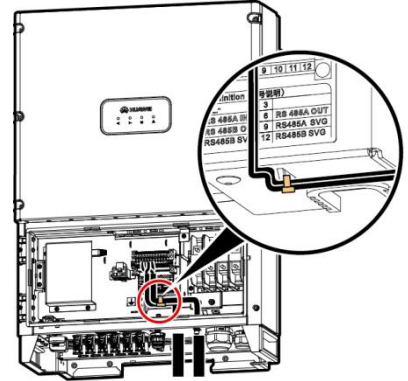

IS02IC0012

NOTICE

1. Route the communications cables through the **COM1** and **COM2** holes at the bottom of the inverter.
 2. Connect the input end to terminals 5 and 7 on the terminal block, and connect the output end to terminals 6 and 8 on the terminal block. Connect the shield layer to the ground point.
 3. The OT terminal used for connecting to the shield layer is in the type of M4.
 4. If multiple inverters are connected over communications cables, ensure that RS485A and RS485B of the previous inverter connect to RS485A and RS485B of the following inverter, respectively.
4. Secure the cable routing pipe.

Method 2: Connecting to RJ45 Ports

You are advised to use a CAT 5E outdoor shielded network cable with a diameter less than 9 mm (0.35 in.) and internal resistance no greater than 1.5 ohms/10 m (1.5 ohms/393.70 in.).

1. Prepare an RS485 connector.

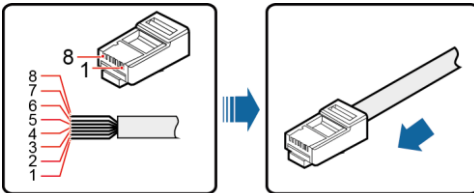

IS01ZC0021

The figure shows the connector when the surface without the fastener faces upwards. The following table lists the cable No., color, and pin definition.

No.	Color	Pin Definition
1	White-and-orange	RS485A, RS485 differential signal +
2	Orange	RS485B, RS485 differential signal -
3	White-and-green	NC
4	Blue	RS485A, RS485 differential signal +
5	White-and-blue	RS485B, RS485 differential signal -
6	Green	NC
7	White-and-brown	NC
8	Brown	NC

2. Connect the RS485 communications cables.

3. Bind the RS485 communications cables.

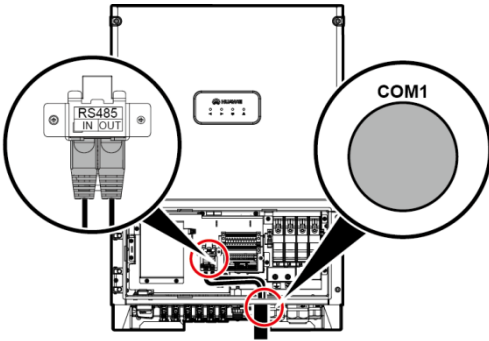

IS02IC0008

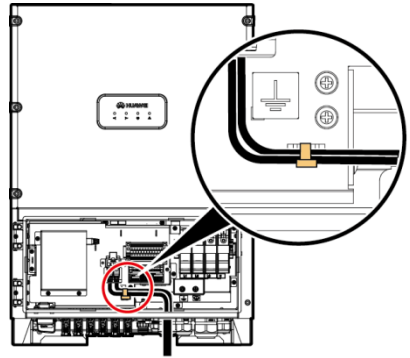

IS02IC0011

4. Secure the cable routing pipe.

NOTICE

1. Route the network cables into the **COM1** hole at the bottom of the inverter.
2. Insert the connectors into the **RS485 IN** and **RS485 OUT** ports in the maintenance compartment of the inverter.
3. Block unused waterproof cable connectors with waterproof plugs.

4 Installation Verification

1. The SUN2000 is installed correctly and securely.	Yes <input type="checkbox"/> No <input type="checkbox"/>
2. All circuit breakers are switched to OFF.	Yes <input type="checkbox"/> No <input type="checkbox"/>
3. Cables connected are not damaged.	Yes <input type="checkbox"/> No <input type="checkbox"/>
4. Ground cables are connected correctly and securely, with no open circuit or short-circuit.	Yes <input type="checkbox"/> No <input type="checkbox"/>
5. AC output power cables are connected correctly and securely, with no open circuit or short-circuit.	Yes <input type="checkbox"/> No <input type="checkbox"/>
6. The DC input voltage is not higher than 1000 V and meets the local voltage range requirements.	Yes <input type="checkbox"/> No <input type="checkbox"/>
7. DC input power cables are connected correctly and securely, with no open circuit or short-circuit.	Yes <input type="checkbox"/> No <input type="checkbox"/>
8. RS485 communications cables are connected correctly and securely.	Yes <input type="checkbox"/> No <input type="checkbox"/>
9. Idle DC input terminals are sealed.	Yes <input type="checkbox"/> No <input type="checkbox"/>
10. Idle USB ports are plugged with covers.	Yes <input type="checkbox"/> No <input type="checkbox"/>
11. Idle waterproof cable connectors are plugged and the locking caps are tightened.	Yes <input type="checkbox"/> No <input type="checkbox"/>

NOTICE

After the verification, reinstall the AC terminal cover, adjust the support bar, and close the maintenance compartment door. Then, tighten the two screws on the door to a torque of 4 N·m. Check that the maintenance compartment door is locked.

5 System Power-on

NOTICE





Before switching on the AC circuit breaker between the inverter and the power grid, use a multimeter to check that the AC voltage is within the specified range.

1. Switch on the AC circuit breaker between the inverter and the power grid.
2. Press **DC SWITCH** at the bottom of the inverter and rotate it to the **ON** position.

NOTICE

If the DC input power cables are reversely connected and the DC switch is ON, do not turn off the DC switch immediately. Otherwise, the inverter may be damaged. Wait until the PV string voltage reduces to the safety range. Then, turn off the DC switch, remove the positive and negative connectors, and rectify the connection.

3. (Optional) Measure the temperatures at the joints between the DC terminals and the connectors using a thermometer.
4. Observe the LED indicators to check the inverter operating status.

Indicator	Status	Meaning	
 PV connection indicator	Steady green	At least one PV string is properly connected, and the DC input voltage of the corresponding MPPT circuit is higher than or equal to 200 V.	
	Off	The inverter disconnects from all PV strings, or the DC input voltage of each MPPT circuit is less than 200 V.	
 Grid-tie indicator	Steady green	The inverter is grid-tied.	
	Off	The inverter is not grid-tied.	
 Communication indicator	Blinking green (on for 0.5s and off for 0.5s)	The SUN2000 receives communications data normally.	
	Off	The SUN2000 receives no communications data for 10s.	
 Alarm/ Maintenance indicator	Alarm state	Blinking red slowly (on for 1s and then off for 4s)	The inverter has generated a warning.
		Blinking red fast (on for 0.5s and then off for 0.5s)	The inverter has generated a minor alarm.
		Steady red	The inverter has generated a major alarm.
	Local maintenance state	Blinking green slowly (on for 1s and then off for 1s)	Local maintenance is in progress.
		Blinking green fast (on for 0.125s and off for 0.125s)	Local maintenance has failed.
		Steady green	Local maintenance is successful.

6 SUN2000 APP

NOTE

1. The SUN2000 app is a mobile phone app that communicates with the SUN2000 monitoring system over a USB data cable, a Bluetooth module, or a WLAN module. As a convenient local monitoring and maintenance platform, it supports alarm query, parameter settings, and routine maintenance. The app name is **SUN2000**.
2. Access Huawei application store (<https://appstore.huawei.com>) or Google Play (<https://play.google.com>), search for **SUN2000**, and download the app installation package.
3. Connect a USB data cable, a Bluetooth module, or a WLAN module to the USB port of the SUN2000 to implement the communication between the SUN2000 and the app.

WLAN or Bluetooth Connection

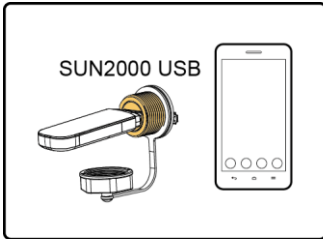

USB Data Cable Connection

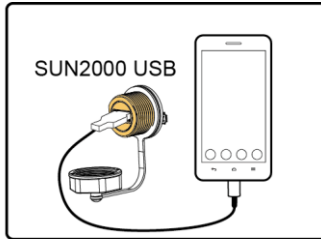

IS07H00020

Login Page

Select Connection Mode

Select User

Quick Settings

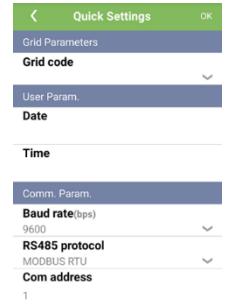
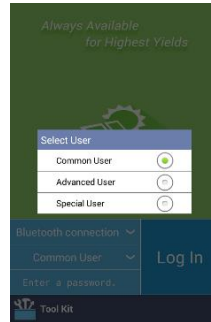
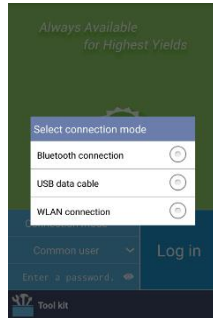

Function Menu



NOTICE

- The screenshots in this document correspond to app version 3.2.00.001 (Android).
- When the WLAN connection is used, the initial name of the WLAN hotspot is **Adapter-WLAN module SN**, and the initial password is **Changeme**.
- The initial password for **Common User**, **Advanced User**, and **Special User** is **00000a**.
- Use the initial password upon first power-on and change it immediately after login. To ensure account security, change the password periodically and keep the new password in mind. Not changing the initial password may cause password disclosure. A password left unchanged for a long period of time may be stolen or cracked. If a password is lost, devices cannot be accessed. In these cases, the user is liable for any loss caused to the PV plant.
- Set the correct grid code based on the application area and scenario of the solar inverter.

7 FAQ

7.1 Why the DC Switch Is Designed with a Hole?

The DC switch is designed with a hole for safety purposes. When maintenance needs to be performed on the inverter, the DC switch must be turned off. To prevent misoperations of turning on the DC switch, the switch must be locked. The design with a hole enables the DC switch to be locked.

7.2 What Is the Purpose of Measuring the Temperatures at the Joints Between DC terminals and Connectors Using a Point-Test Thermometer?

After the inverter has been running for a period, use a point-test thermometer to measure the temperatures at the joints between DC terminals and connectors to check that the DC terminals are in good contact.

Appendix: Power Grid Code Mapping Table

No.	Power Grid Standard Code	Country and Condition
1	IEEE 1547-MV480	US medium-voltage power grid
2	IEEE 1547a-MV480	2016 US medium-voltage power grid
3	PRC_024_ERCOT-MV480	Texas medium-voltage power grid
4	PRC_024_Eastern-MV480	Eastern US medium-voltage power grid
5	PRC_024_Western-MV480	Western US medium-voltage power grid
6	PRC_024_Quebec-MV480	Quebec medium-voltage power grid
7	ELEC RULE NO.21-MV480	California medium-voltage power grid
8	HECO-MV480	Hawaii medium-voltage power grid

NOTE

The grid codes are subject to change and are for your reference only.

Huawei Technologies Co., Ltd.
Huawei Industrial Base, Bantian, Longgang
Shenzhen 518129 People's Republic of China
www.huawei.com